



# 2 • Fluid Level Management



---

Introduction .....	2-3
<b>REN™ Oil Level Regulator .....</b>	<b>2-5</b>
<b>REN™ Slow Flow Meter .....</b>	<b>2-9</b>
Slow Flow Meter Remote Readout .....	2-12
<b>REN™ Continuous Oil Change Module .....</b>	<b>2-13</b>
<b>REN™ Liquid Level Switch .....</b>	<b>2-15</b>
<b>REN™ Oil Supply Reservoirs .....</b>	<b>2-17</b>
<b>Discontinued Products .....</b>	<b>2-19</b>

## REN™ Fluid Level Management Products

Certain stationary applications, such as Oil & Gas Pumping/Compressing stations, as well as power generation and agricultural irrigation systems, require fluid level management systems to ensure that the engine is always lubricated. These stations are typically found in remote areas with several applications spread out over many acres being maintained by only one person. For this reason, the REN Fluid Level Management System was developed. This system allows you to pick and choose components to build your own system to meet your specific needs.

### Oil Level Regulator

The Oil Level Regulator is the foundation of the fluid level management system. It provides a visual line-of-site into the oil pan to easily see the oil level in the oil sump. The regulator can also utilize an integrated switch tied to an external clean oil tank which can add oil when the sump reaches a certain level. Since uptime is critical to these applications, the Oil Level Regulator ensures that engine is always producing as intended.

### Slow Flow Meter

The second key component of a good preventive maintenance program is a Slow Flow Meter. This meter allows the maintenance manager to measure exactly how much clean oil is added to the system each month, especially when the meter is used in combination with an Oil Level Regulator and a clean oil tank. Maintaining accurate records of the add oil rate will assist a maintenance manager in determining when to schedule an engine rebuild, possibly avoiding an engine failure. The meter is available with both analog and digital readouts; the digital readout can be wired into a wireless system to allow for remote data retrieval.

### Continuous Oil Change Module

The Continuous Oil Change Module can be combined with the other mentioned components to allow used oil to be burned as fuel. This also provides the benefit of adding clean oil to the system as well as all of the benefits of an updated additive package. Adding clean oil to the system can be especially important in some oil and gas fields where acidic sour gas is burned in the engine, thereby quickly reducing the TBN of the oil. Additionally, added oil can minimize the impact on the oil drain and preventive maintenance interval.

Combining all of these components together into one system, or picking and choosing which of these building blocks are the optimal components of your maintenance system, is one the benefits of this modular system.

### Liquid Level Switch

One last REN component not related to the above system is a Liquid Level Switch. This product uses a simple switch to signal a shut-off valve, or to signal the opening of a valve to fill a necessary fluid.

The REN product line is a durable product group that has proven itself since the 1940s. This product was designed specifically for the demands of the Industrial Markets worldwide. There is no better product for your stationary preventive maintenance program.

# Introduction

---



This page left blank intentionally.



# REN™ Oil Level Regulator

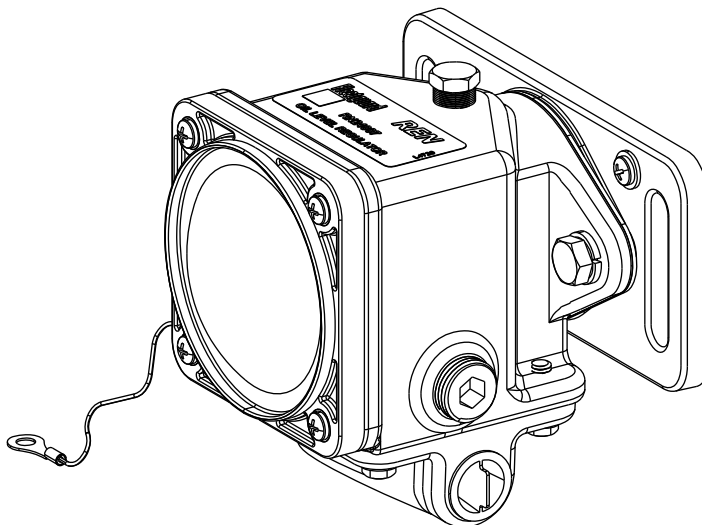

## Specifications

Specification	REN™ Oil Level Regulator
Height Overall (Without Bracket)	5.00" (136.53 mm)
Depth Overall	7.13" (180.98 mm)
Width, Max. (Without Bracket)	4.38" (111.13 mm)
Mount Bracket Centers	5.26" (133.60 mm)
Weight (Dry)	9 lbs (4.08 kg)
Fuel Oil Connections (Inlet)	1.2" NPT
Fuel Oil Connection (Outlet)	1.2" NPT
Min Vent Hose (I.D.)	3/8" (9.53 mm)
Max Inlet Pressure	4 in <sup>2</sup> (27.58 kPa)

For multicylinder engines only.  
Specifications subject to change without notice.

## Parts List

Part	Description	Part Number
A	Front Window Kit – One Piece Isoplast with Gasket and Screw Set	3945565 S
B	Valve Assembly With Float	3946910 S
C	Valve Gasket	3945567 S
D	Sediment Bowl Screen and Gasket Combo	3967685 S
E	Sediment Bowl Inlet (supplied as part of Sediment Bowl Service Kit)	3946906 S
	Metal Sediment Bowl Service Kit	3965311 S
F	Assembly Screw Set	3946911 S
G	1/2" NPT Plug	3946905 S
H	Switch Assembly	3945562 S
I	Body Casting	N/A
J	Unvented 1/4" NPT Plug	3946907 S
K	Mounting Plate Gasket	3945563 S

Part	Description	Part Number
L	Slotted Mounting Plate	3946908 S
M	Aluminum "Y" Mounting Bracket	3946909 S
	Slotted Aluminum "Y" Mounting Bracket (not shown)	3968805 S
N	Hose Clamps (4 Required)	N/A
O	1/2" NPT Barbed Nipples (4 Required)	3945560 S
P	Neoprene Hose	N/A
Q	Front Ring Screw Set	3945569 S
R	Front Ring	3948644 S
S	Front Window – Glass	3945207 S
T	Window Gasket (2 required – each side of window)	3945568 S
U	Complete Gasket Set (Not shown - Includes parts A1, C, D, K, and L)	3945217 S

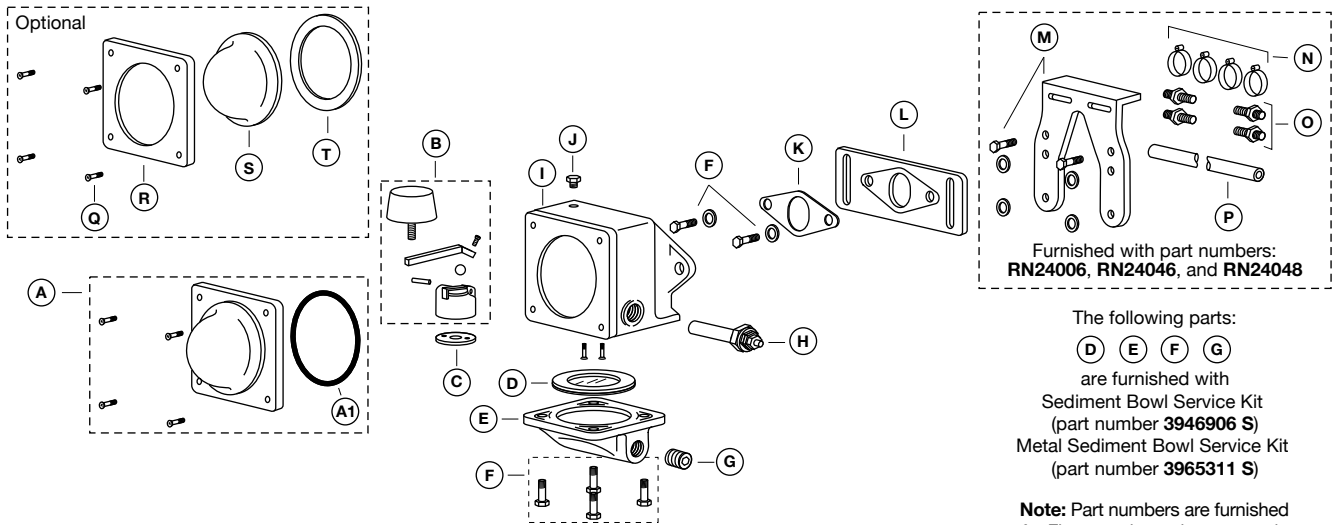

Ordering Information

Part Number	Description
RN24006	Oil Level Regulator with mounting bracket, hose and fittings
RN24007	Oil Level Regulator without mounting bracket, hose and fittings
RN24046	Oil Level Regulator with metal bowl, mounting bracket, hose, and fittings
RN24048	Oil Level Regulator with 1/2" slotted mounting bracket, hose, and fittings

Mounting/Dimensions

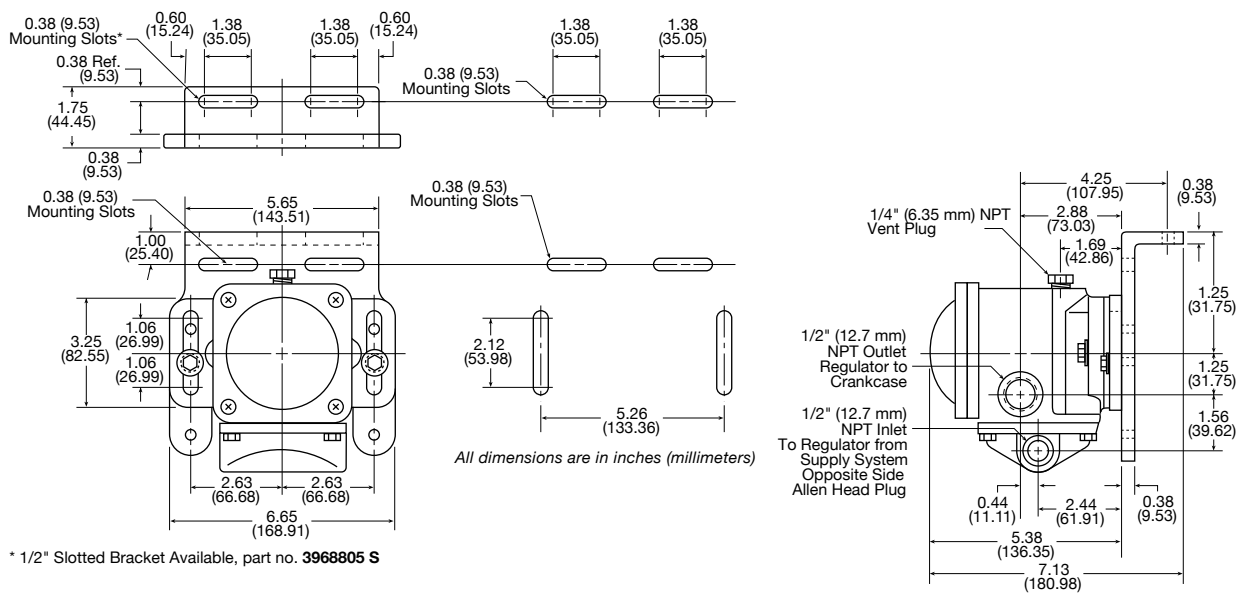

Typical Installation

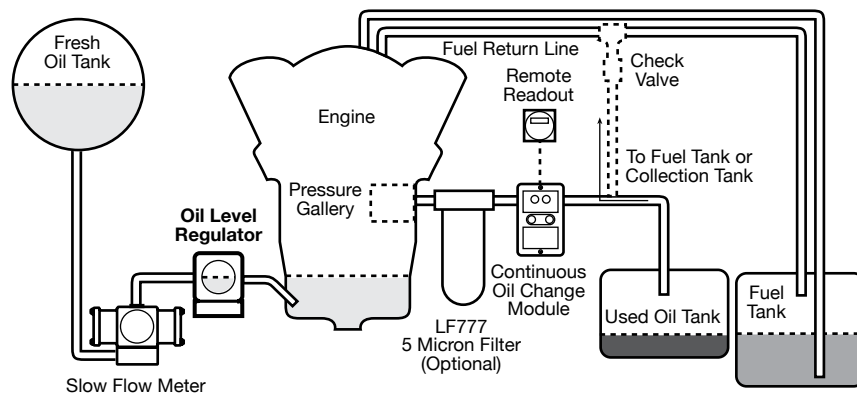





# REN™ Slow Flow Meter

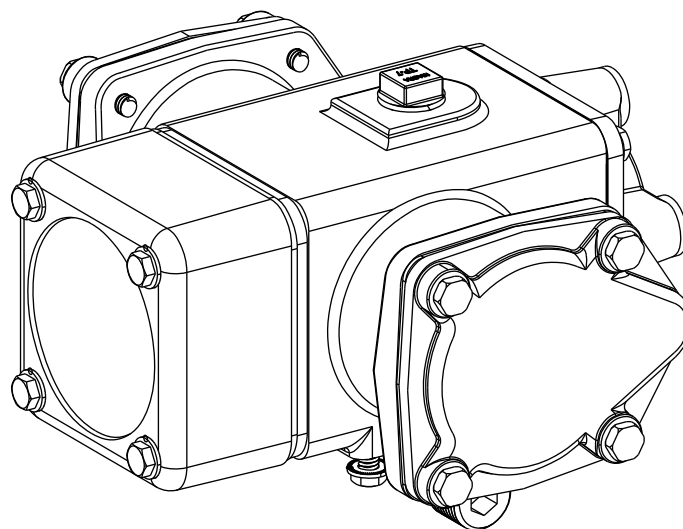

## Specifications

Specification	REN™ Slow Flow Meter
Height Overall	7.875" (200.03 mm)
Length Overall	5.375" (136.53 mm)
Width, Max.	8.00" (203.20 mm)
Weight	6.75 lbs (3.00 kg)
Max Flow	10 gal/h (37.85 L/h)
Min Inlet Pressure	3.5 lb/in <sup>2</sup> (24.13 kPa)
Max Inlet Pressure	100 lb/in <sup>2</sup> (689.47 kPa)
Accuracy	0.5%

Specifications subject to change without notice.

**Note:** An intrinsically safe device is designed in such way so that energy it holds cannot ignite the gases, vapors or combustible dusts existing in the atmosphere of the designated area. Our Intrinsically Safe readout was approved for use in areas where flammable gases may be present in sufficient quantities to produce explosive or flammable mixtures. In those areas, flammable gases, vapors, liquids, combustible dusts or ignitable fibers are likely to exist under normal operating conditions. Atmosphere may contain ethyl-ether vapors, ethylene, or cyclo-propane, gasoline, hexane, naphtha, benzene, butane, propane, alcohol, acetone, benzol, lacquer solvent vapors, or natural gas.

## Parts List

Part	Description	Part Number
A	Inlet Sediment Bowl Kit	3946906 S
B	Pressure Regulator Kit	3945581 S
C	Piston Assembly Kit	3952332 S
D	Cycling Valve Kit	3952436 S
E	Intrinsically Safe Counter Assembly with Digital Readout	See Ordering Information
F	Counter Cover Gasket	3945852 S
G	Regulator Gasket Set Kit (not shown)	3945217 S
H	Meter Gasket Set Kit (not shown)	3945220 S
I	Screw Set Kit (not shown)	3950385 S

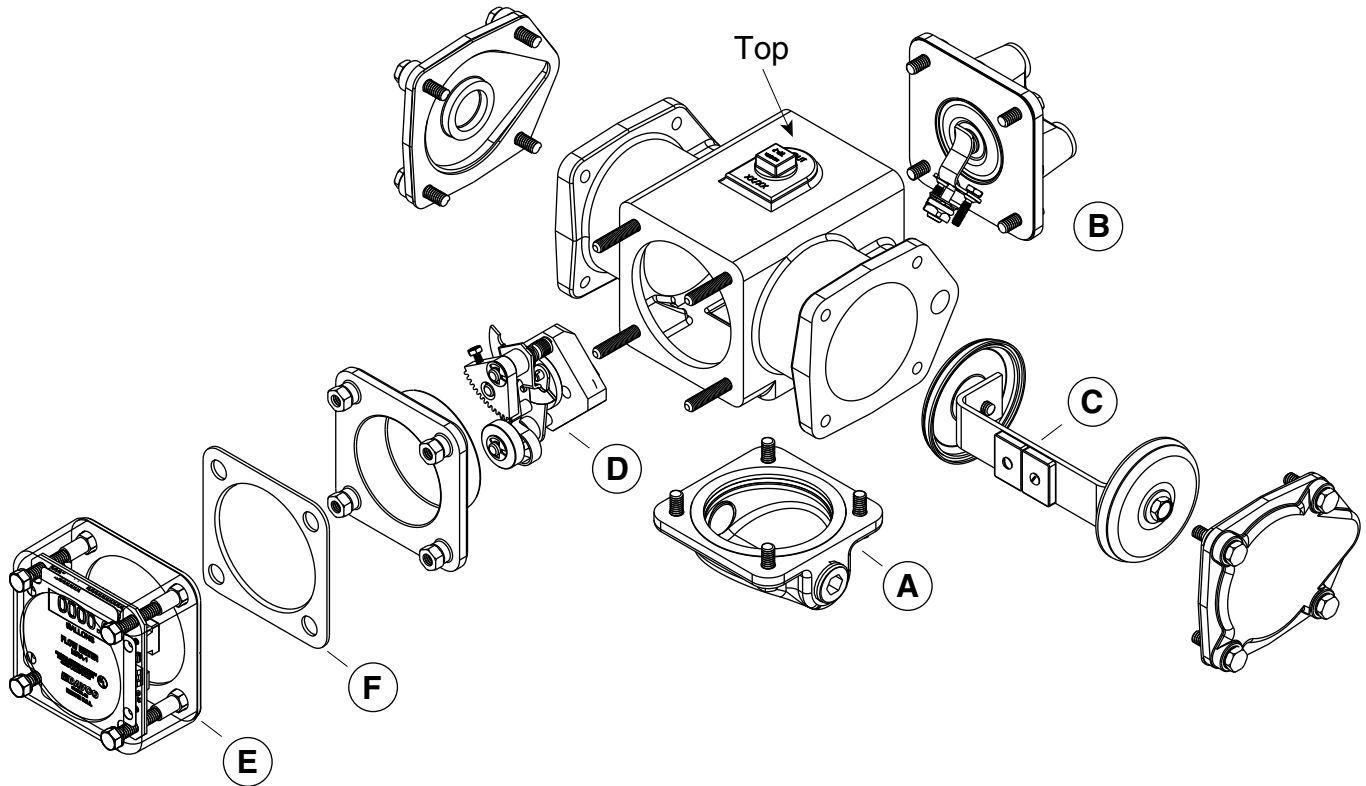

Ordering Information

Part Number	Description
RN24044	Slow Flow Meter – Intrinsically safe with digital readout (gallon)
RN24045	Slow Flow Meter – Intrinsically safe with digital readout (liter)
RN24026	Slow Flow Meter without display for connection to PLC or remote readout

Mounting/Dimensions

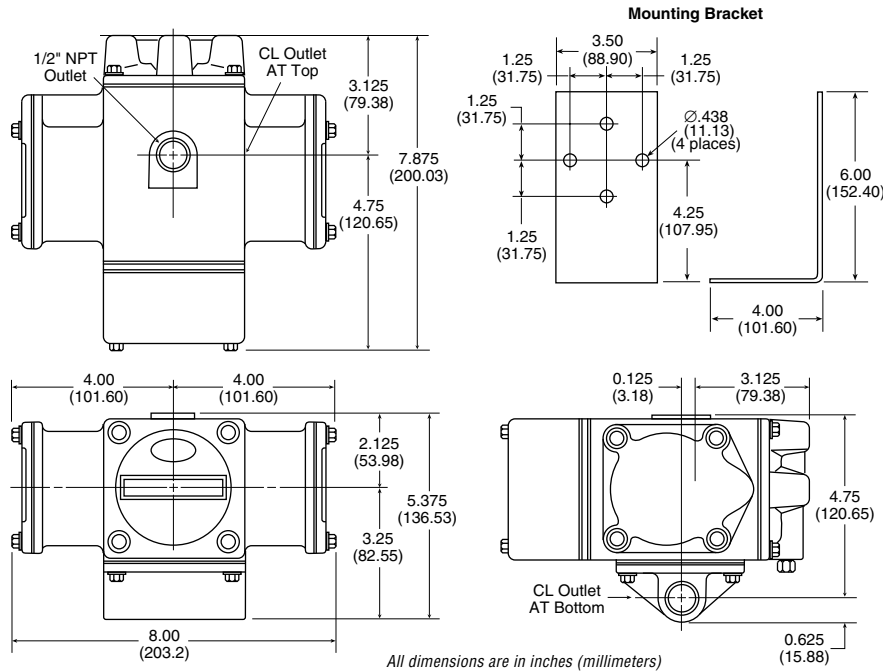

Typical Installation

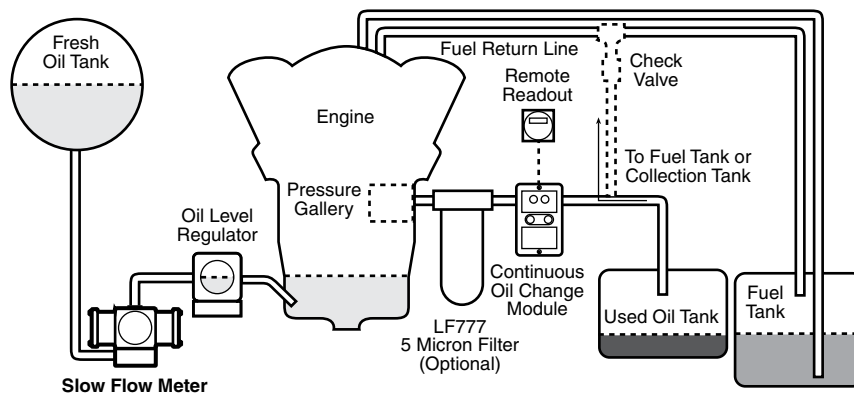

## Ordering Information

Part Number	Description
<b>3945222 S</b>	LCD Remote Readout Kit*
<b>3946512 S</b>	LCD Single Readout Only (liter)*
<b>3950397 S</b>	Complete Remote Readout Kit (gallon)
<b>3953480 S</b>	Five Year Life Lithium Battery

\* Together, these two parts comprise a complete remote readout kit in liters.

## Installation

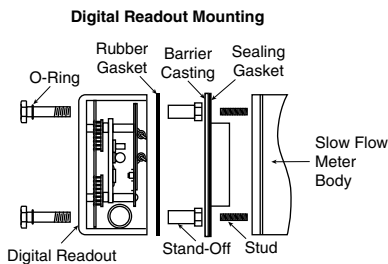
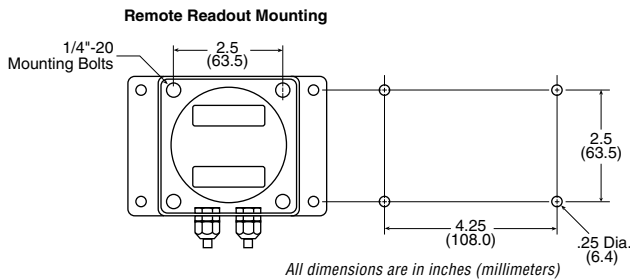

## Specifications

Specification	Slow Flow Meter Remote Readout
Height	3.375" (85.7 mm)
Depth Overall	1.75" (44.5 mm)
Width, Max.	5" (127.0 mm)
Weight	1 lb (0.45 kg)
Count, Max.	9999.9 gal or 9999.9 L in 0.05 gal (0.25 L) Increments
Readout	Volume or Volume vs Time
Accuracy	0.5%

Specifications subject to change without notice.

# REN™ Continuous Oil Change Module

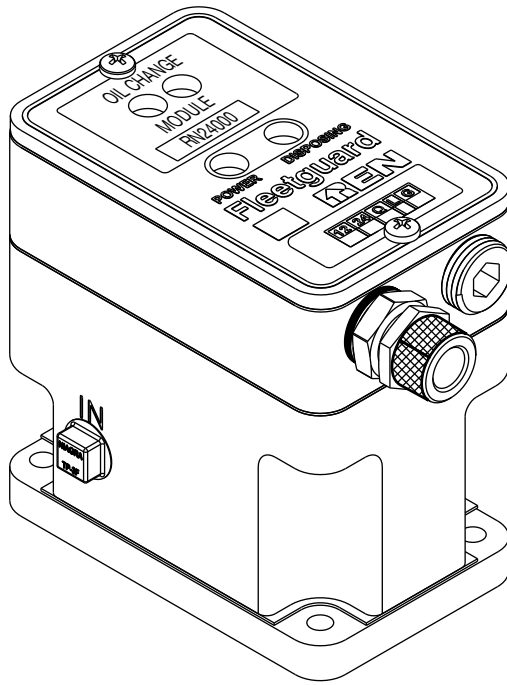

## Specifications

Specification	REN™ Continuous Oil Change Module
Height Overall	5.20" (132.1 mm)
Depth Overall	4.80" (121.9 mm)
Width, Max.	3.00" (76.2 mm)
Weight (Dry)	5.2 lb (2.4 kg)
Fuel Oil Connections (Inlet)	1/4"-18 NPTF
Fuel Oil Connection (Outlet)	1/4"-18 NPTF
Power (1 W Avg, 12 W Peak)	12 VDC (+4/-0 V) 24 VDC (+4/-0 V)
Disposal (Adjustable)	0.01 - 0.99 units/h
Operating Temperature	0 - 212 °F (-20 - 100 °C)
Min Temperature	-40 °F (-40 °C)
Max Temperature	248 °F (120 °C)
Min Oil Pressure	30 lb/in <sup>2</sup> (206.8 kPa)
Max Oil Pressure	100 lb/in <sup>2</sup> (689.47 kPa)

Protected against reversed supply polarity and negative spikes to 500.  
Specifications subject to change without notice.

## Ordering Information

Part Number	DC Voltage	Unit of Measure
RN24000	12	Gallon
RN24001	24	Gallon
RN24002	12	Liter
RN24003	24	Liter
RN24004	12	Quart
RN24005	24	Quart

## Mounting/Dimensions

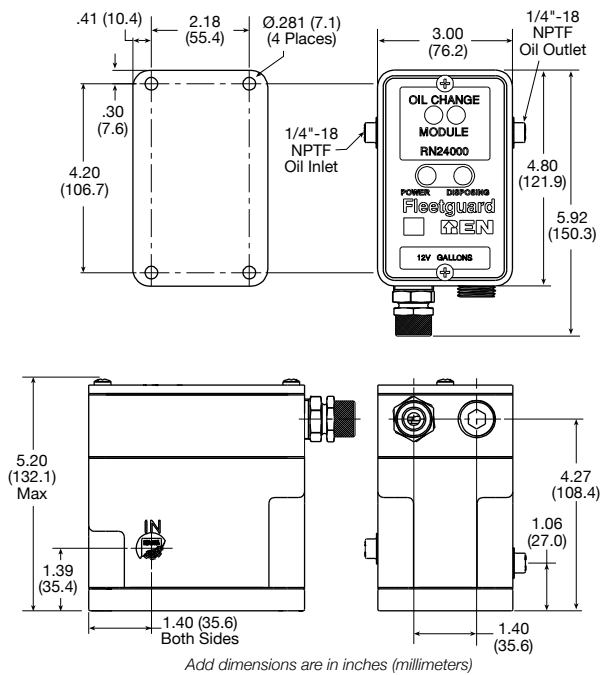

## Typical Installation

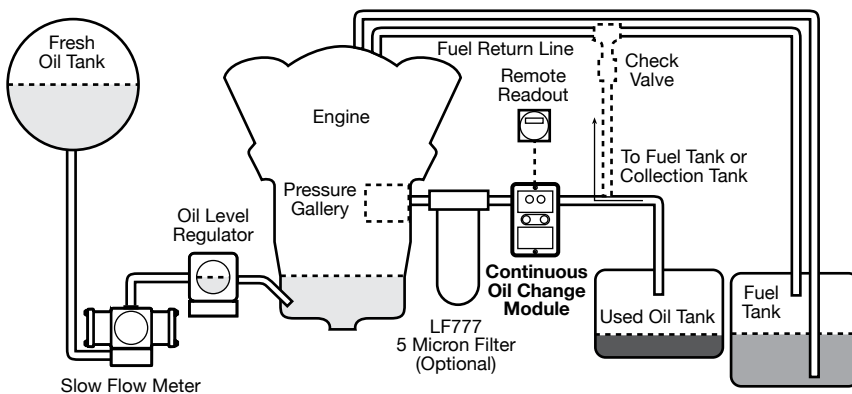

# REN™ Liquid Level Switch

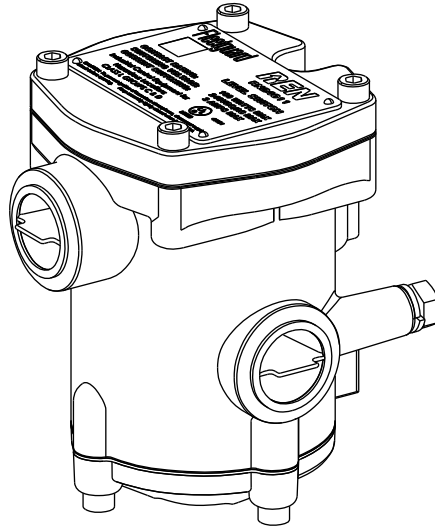

## Specifications

Specification	REN™ Liquid Level Switch
Height Overall	4.60" (116.84 mm)
Depth Overall	3.60" (91.44 mm)
Width, Max.	3.04" (77.22 mm)
Weight	1 lb 12 oz (0.79 kg)
Switching Level (Petroleum Based Liquids)	±0.12" (3.05 mm)
Switching Hysteresis	0.06" (1.52 mm) Min. 0.12" (3.05 mm) Max.
Temperature Range	-40 °F to 248 °F (-40 °C to 120 °C)
Fluid Seal Temperature, Max.	275 °F (135 °C) Max.
Switching Current, Max	3 A Max.
Switching Voltage, Max.	240 VAC/DC Max.
Switching Power, Max.	100 W, DC/VA Max.

UL Listed 4N51, Class I, Groups C & D Hazardous Locations.  
Specifications subject to change without notice.

## Ordering Information

Part Number	Description
RN24011	Liquid Level Switch

## Mounting/Dimensions

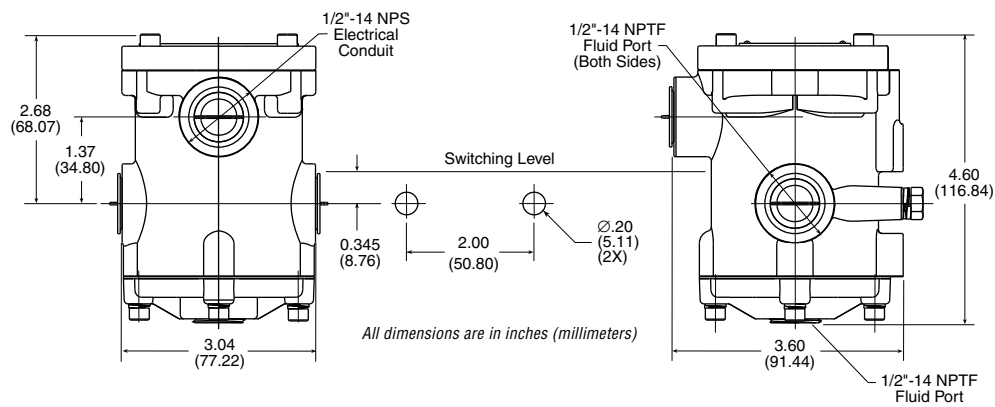



# REN<sup>TM</sup> Oil Supply Reservoirs

**5 Gallon  
(18.9 Liter)**

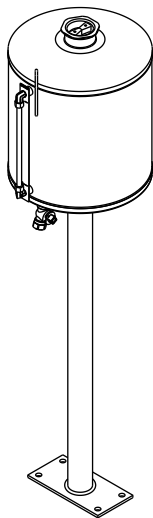

**15 Gallon  
(56.8 Liter)**

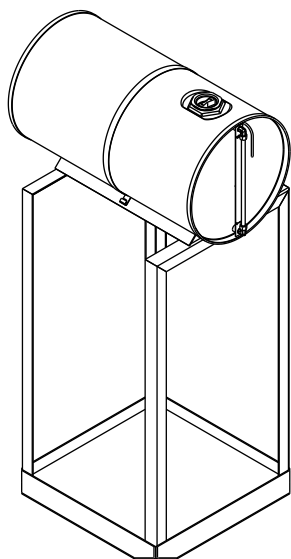

**30 Gallon  
(113.6 Liter)**

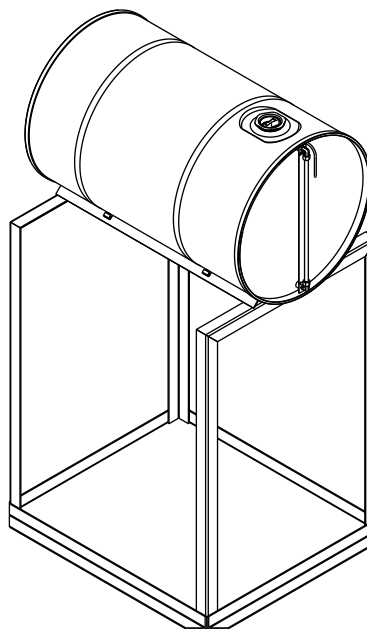

## Specifications

Specification	RN24012	RN24015	RN24017
Height Overall	45.52 in (115.62 cm)	51.13 in (129.87 cm)	54.73 in (139.01 cm)
Tank Height	16.27 in (41.32 cm)	28.00 in (71.12 cm)	30.00 in (76.20 cm)
Tank OD	12.00 in (30.48 cm)	14.31 in (36.35 cm)	18.87 in (47.93 cm)
Holding Capacity	5 gal (18.9 L)	15 gal (56.8 L)	30 gal (113.6 L)
Mounting Stand	Yes	Yes	Yes

Specifications subject to change without notice.

## Ordering Information

Part Number	Description
<b>RN24012</b>	5 gallon (18.9 liter) Oil Supply Reservoir and pedestal stand
<b>RN24015</b>	15 gallon (56.8 liter) Oil Supply Reservoir and stand
<b>RN24017</b>	30 gallon (113.6 liter) Oil Supply Reservoir and stand

Part Number	Description
<b>3946389 S*</b>	Universal Mounting Bracket for 15 gallon (56.8 liter) Oil Supply Reservoir and pedestal stand
<b>3946390 S*</b>	Universal Mounting Bracket for 30 gallon (113.6 liter) Oil Supply Reservoir and stand

\* Available at additional cost.

## Mounting/Dimensions

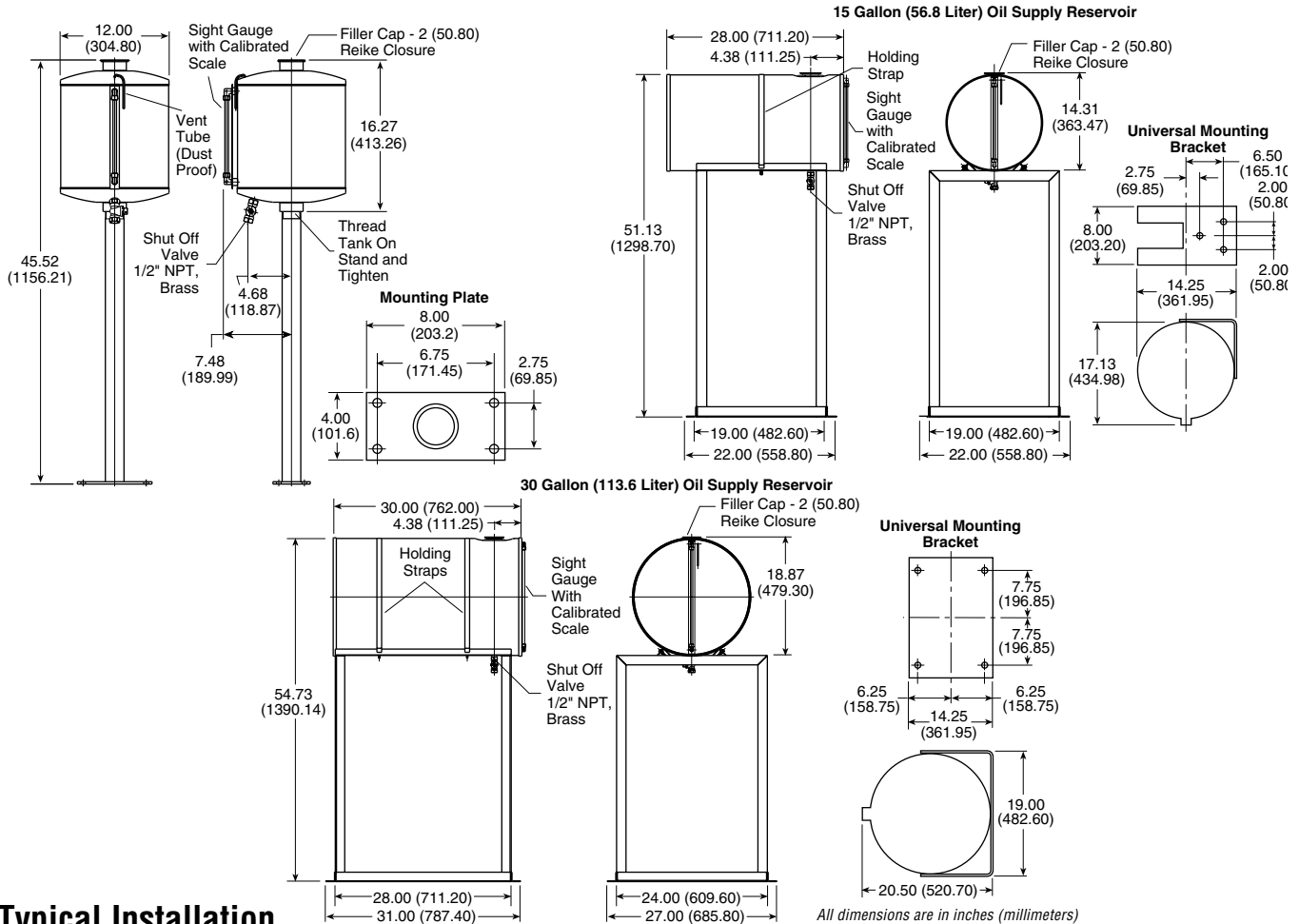

## Typical Installation

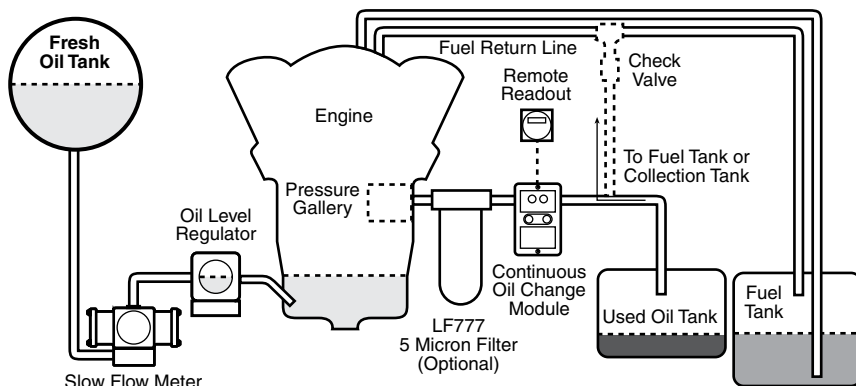



# Discontinued Products

---

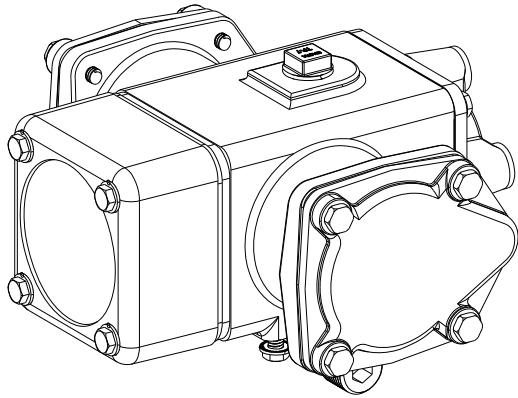

## REN™ Slow Flow Meter

Part Number	Description
<b>RN24008</b>	Analog Slow Flow Meter with counter (gallon)
<b>RN24010</b>	Analog Slow Flow Meter with counter (liter)
<b>RN24018</b>	Digital Slow Flow Meter with LCD readout (gallon)
<b>RN24021</b>	Digital Slow Flow Meter with LCD readout (liter)